

IP OFFICE: OPPORTUNITIES AND TOOLS FOR BUSINESS AND SCIENCE



The National Intellectual Property Authority (NIPA), the functions of which commenced on 8 November 2022 pursuant to the Order of the Cabinet of Ministers of Ukraine “Certain Issues of the National Intellectual Property Authority” dated 28 October 2022 No. 943-r.

A state organization authorized to conduct the examination and registration of rights to intellectual property objects, including inventions and utility models, industrial designs, trademarks, geographical indications, topographies of semiconductor products, as well as the state registration of copyright and agreements relating to property rights in works.

It is subordinated to **the Ministry of Economy of Ukraine**.

We develop the national innovation ecosystem through the **National IP & Innovations Hub**, the **TISC network** (Technology and Innovation Support Centers), **regional innovation hubs**, and through cooperation with **stakeholders and business partners**.



Vision

We are building a national intellectual property and innovation ecosystem that drives the development of the innovation and creative sectors of the economy and transforms them into an investment magnet for Ukraine.

We are guided by best international practices in IP management and consider the interests of all stakeholders to ensure balanced development of the sector.



Values

- Transparency
- Efficiency
- Respect
- High-quality services and digitalization
- High standards of governance



IPR Monitoring Center

IP Mediation and Facilitation Center

Intellectual Property Law Development Center

National IP&Innovations Hub

Examination of Applications for Industrial Property Objects

UANIPIO

State registers

IP Academy of Ukraine

Appeals Chamber of the National Office for Intellectual Property

Creative Industries

Copyright and related rights

The "Ukraine" Commission

What are we doing?

1

We conduct examination of intellectual property objects

2

We act as an International Searching Authority (ISA) and an International Preliminary Examining Authority (IPEA), ranking among 25 patent offices worldwide

3

We register rights to intellectual property objects, including copyright works, inventions and utility models, industrial designs, trademarks, geographical indications and topographies of semiconductor products.

4

We support the development of Ukrainian brands through the “Ukraine” Commission.

5

We maintain state registers of intellectual property objects and ensure open access to data.

6

We develop digital tools to support authors, creators, inventors, and innovators.

7

We support the development of innovation through the National IP & Innovations Hub, the TISC network, and regional innovation hubs.

What are we doing?

8

We provide services and advisory support to applicants, businesses, researchers, educators, startups and other stakeholders.

9

We develop innovation infrastructure.

10

We certify patent attorneys and maintain the official register of representatives in intellectual property matters.

11

We contribute to the protection of intellectual property rights through the IPR Monitoring Center, the Mediation and Facilitation Center, the Appeals Chamber, and the national list of infringing websites (WIPO ALERT), in cooperation with law enforcement, customs, and judicial authorities

12

We foster a culture of respect for intellectual property

Appeals Chamber

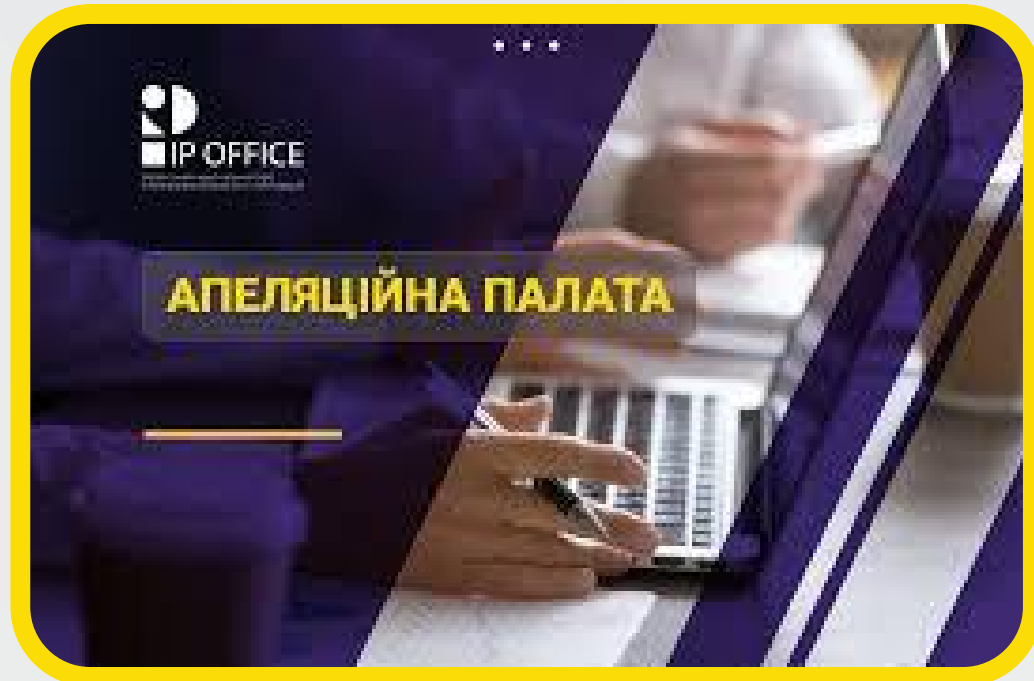

Here you can:

- Apply for recognition of a trademark as well-known in Ukraine;
- Appeal decisions of the IP Office;
- Apply for invalidation of certificates and patents

“Ukraine” Commission

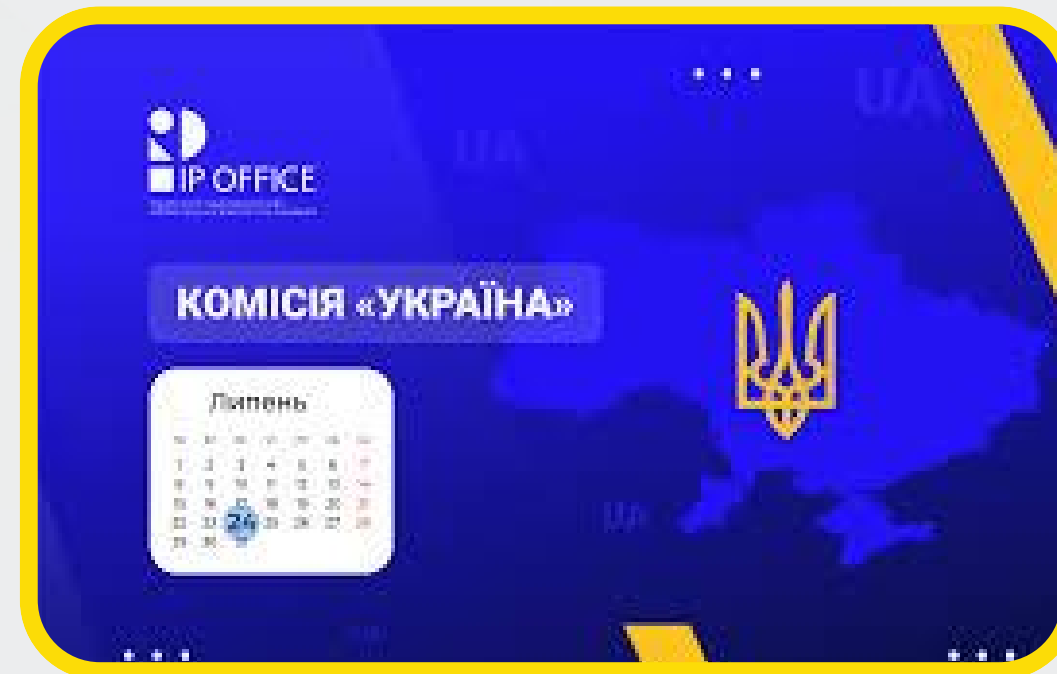

Here you can:

- Apply for authorization to use the official name and/or the international letter code of the State of Ukraine in a trademark;
- Apply for authorization to include an imitation of the Small State Emblem of Ukraine in a trademark.

Mediation and Intermediation Center



Here you can:

- Resolve your IP dispute .

National IP&Innovations Hub

National IP&Innovations Hub is a powerful innovation-driven centre that supports research, development, commercialisation of intellectual property rights objects and technology transfer, encourages investment in Ukraine's economy and contributes to job creation.

- A wide range of services in the field of IP and innovation.
- Creation and development of an information cluster.
- Creation and support of innovation infrastructure and its regional network.
- A knowledge hub for intellectual property and innovation.



National IP&Innovations Hub

200+

IP and innovation events organised by the National IP&Innovations Hub and the TISC network.

47

Technology and Innovation Support Centres

4

Regional Innovation Hubs

45+

Information and Analytical Products

10000+

Inventors, innovators, authors and creators have acquired new knowledge and skills

50+

Support for Innovative Projects

4 key facts you need to know about intellectual property and the IP system

- IP provides you with a clear business advantage over your competitors.
- It is important to understand which IP you own and which IP you need permission to use.
- It is crucial to know what IP belongs to others and which rights you may infringe.
- IP is an intangible asset and can be recognised as such on your company's balance sheet, thereby increasing its value and attractiveness for investment, sale or merger.



What role does intellectual property play in your project? How does your IP strategy impact your business strategy?

Regardless of the products or services produced or offered, the use and creation of intellectual property objects are regulated in both science and business.

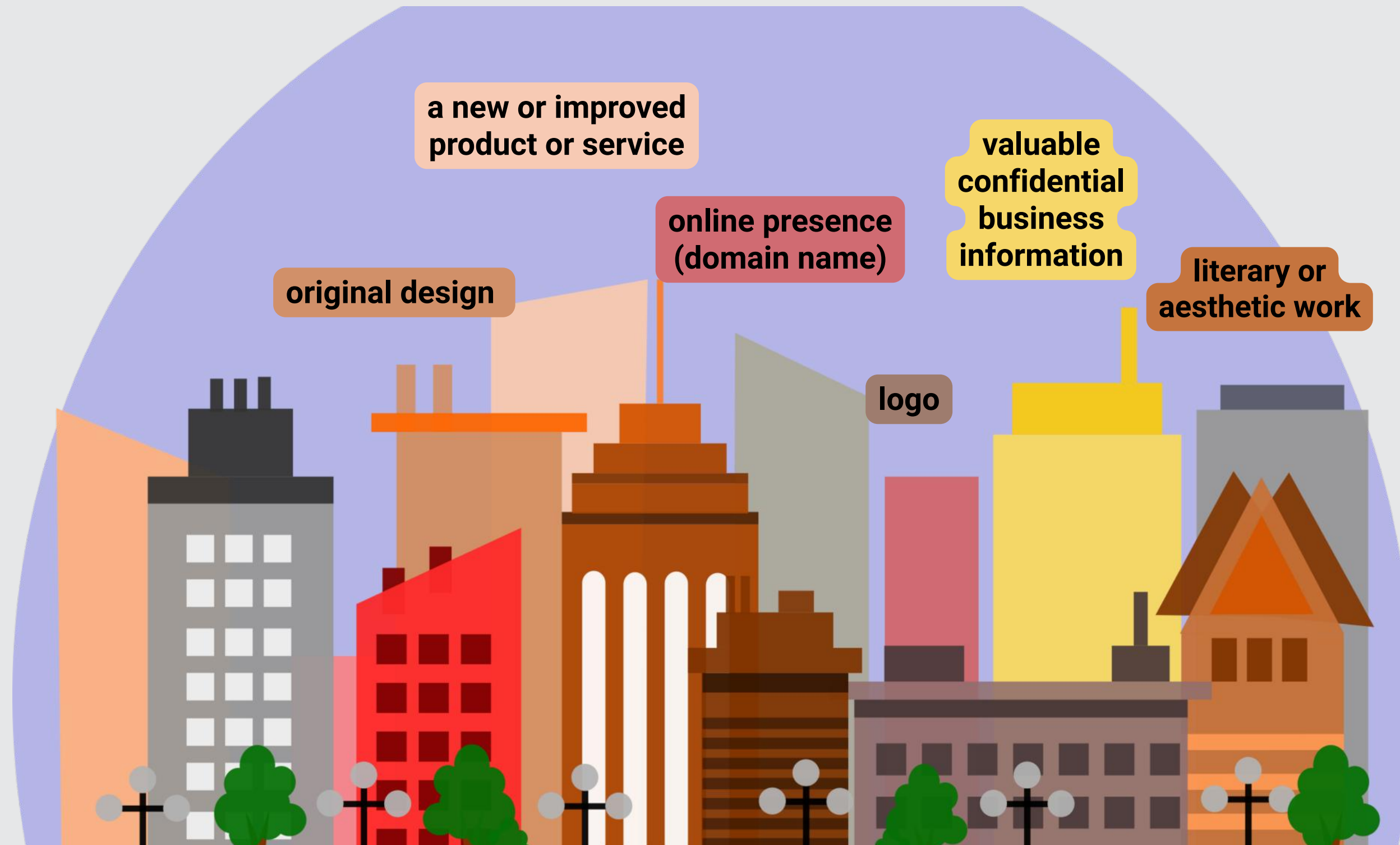

Main objects of intellectual property law

**YOUR PRODUCT IS UNIQUE. DON'T LET OTHERS BENEFIT FROM THE FRUITS OF YOUR WORK.
REGISTER EVERYTHING THAT CREATES VALUE FOR YOUR BUSINESS!**

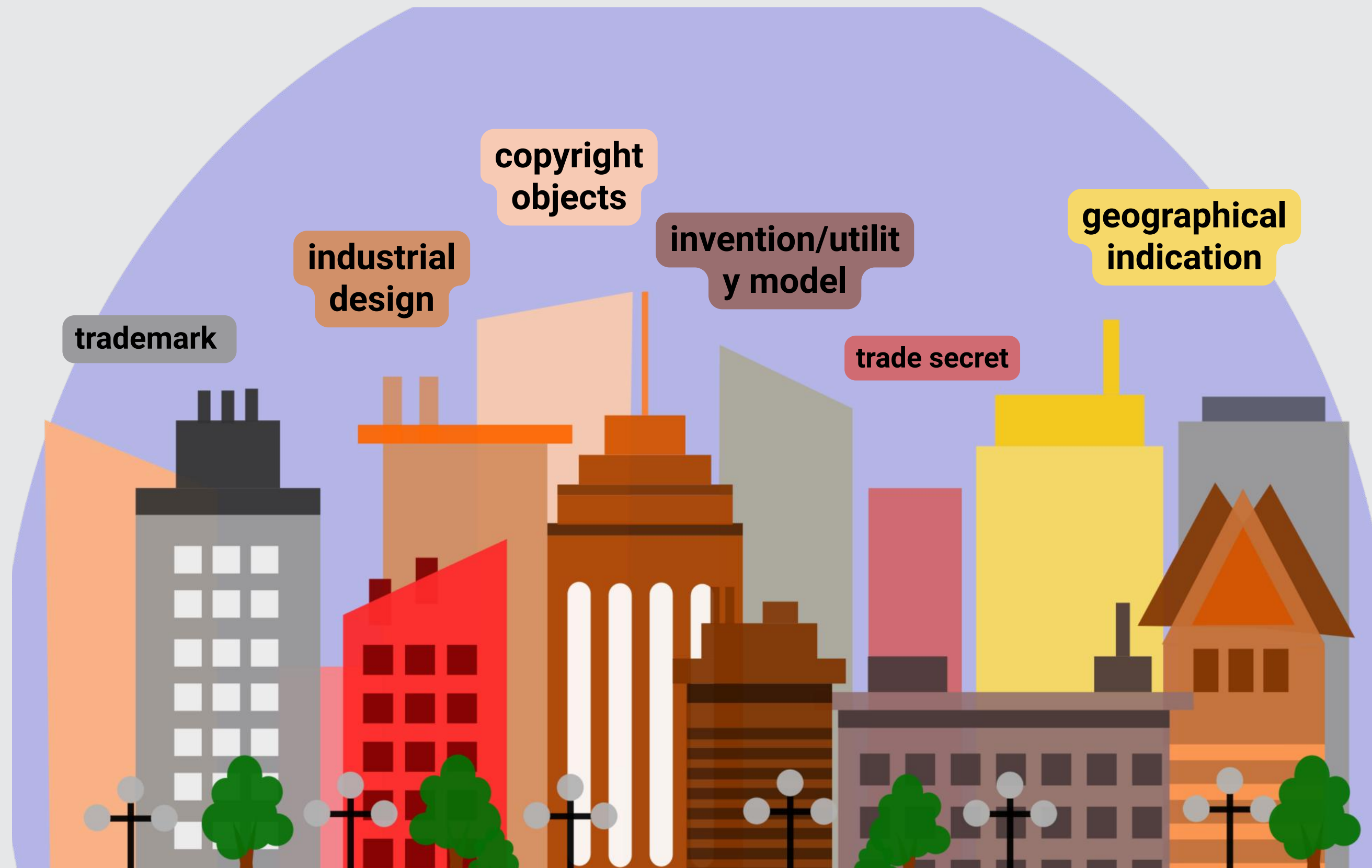

Copyright

Copyright registration is not mandatory and is carried out only at the author's request.

Copyright registration is an important step for businesses in education, marketing, design, IT, and other creative industries. It protects your ideas and enhances the value of your business.

Protection document means a certificate issued on the basis of a decision on the state registration of copyright in a work.

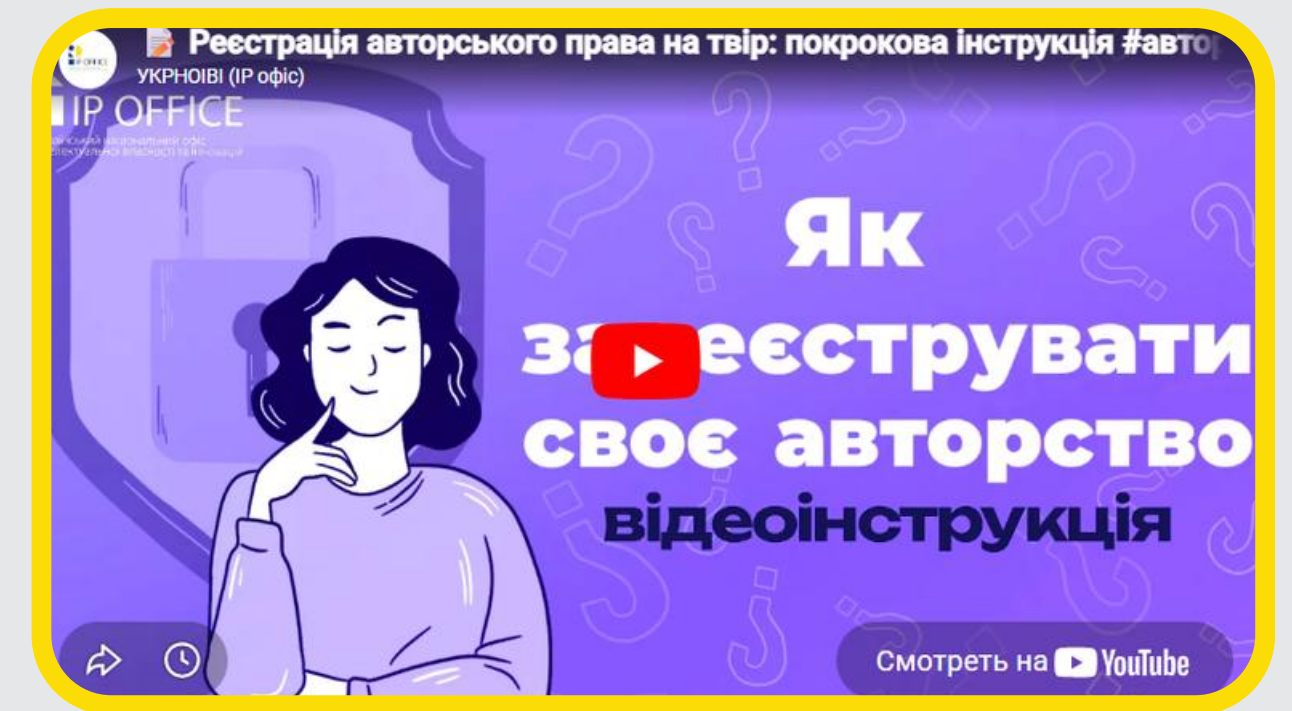

What is the cost of state registration?

Preparation of documents for the state registration of copyright for legal entities – UAH 510.

Preparation of documents for the state registration of copyright for individuals – UAH 255.

The term of copyright shall extend for the life of the author and for 70 years after their death.

Trademarks

A trademark is a designation by which the goods and services of one person are distinguished from the goods and services of another person.

Legal protection shall be granted to a trademark that is not contrary to public order or generally accepted principles of morality and to which the grounds for refusal of legal protection established by the Law of Ukraine “On Protection of Rights to Marks for Goods and Services” do not apply.

The title of protection for a trademark is a certificate.

The certificate is valid for 10 years from the filing date of the application and may be renewed for successive 10-year periods at the request of the certificate holder, subject to payment of the prescribed fee.

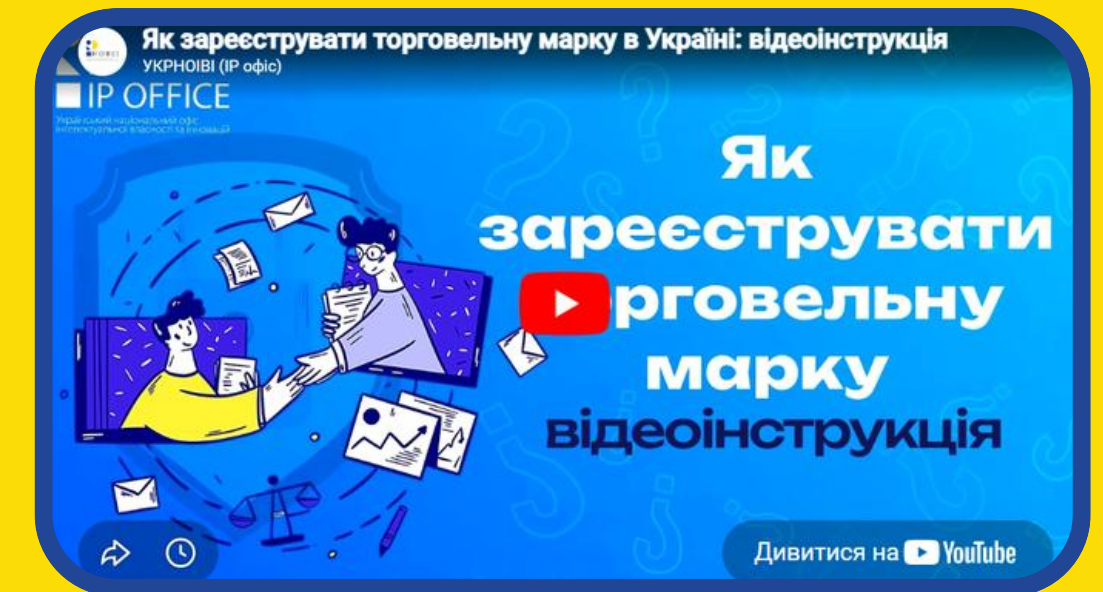

Trademark registration is a key step in protecting a business and a brand, providing exclusive rights to use the name and logo, protection against unfair competition and cybersquatting, as well as a guarantee of authenticity for consumers.

What is the cost of state registration?

The fee for filing a trademark application by one applicant is **UAH 4,000**. An additional fee of **UAH 4,000** is charged for each additional class.

An additional fee of **UAH 1,000** is charged for filing a colour image of the trademark in the application.

Trademarks



APPLE

Word mark



Figurative mark

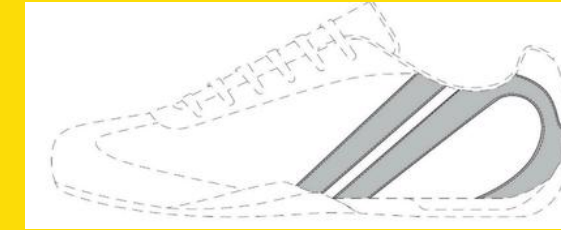

Position mark



Apple Watch

Combined mark



Pattern mark



Shape mark



Sound mark

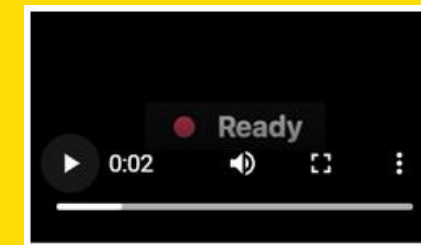

Motion mark

Well-known trademarks

Well-known trademarks are trademarks that have been recognized as well-known in Ukraine by a decision of a competent state authority or a court.

Advantages:

- protection is granted without mandatory registration by virtue of being well-known;
- extends to both related goods and services and those unrelated to the goods and services for which the trademark has been recognized as well-known in Ukraine;
- receives protection not from the date of the decision, but from the date for which the applicant seeks legal protection;
- the term of protection is not limited;
- increases the value of the trademark as an intangible asset and serves as an indicator of a high level of public recognition;
- the owner is entitled to demand prohibition of the use of a designation, a component of which reproduces a well-known mark.



ФОРА



СІЛЬПО



ROZETKA

Technical solutions

If a business is based on an industrially applicable technical solution that is new to the market, it is advisable to consider registering it as an invention or a utility model and obtaining the relevant patent.



Patents grant exclusive rights to use the invention, enhance technological and innovation capacity, facilitate licensing, increase a company's value, and strengthen its reputation as an innovation leader.

Invention

An invention (utility model) is the result of a person's intellectual and creative activity in any field of technology.

An object of an invention for which legal protection is granted may be a product (device, substance, strain of microorganism, culture of plant or animal cells, etc.) or a process (method).

Legal protection shall be granted to an invention that does not contradict public order or generally accepted principles of morality and meets the patentability requirements.

An invention meets the patentability requirements if it is:

- new;
- involves an inventive step;
- industrially applicable.

The term of validity of intellectual property rights to an invention shall be 20 years from the filing date of the application.

A patent is a title of protection.

The fee for filing an application (international application) for an invention containing no more than three claims is **UAH 1,600**.
An additional fee of **UAH 160** shall be paid for each claim in excess of three.

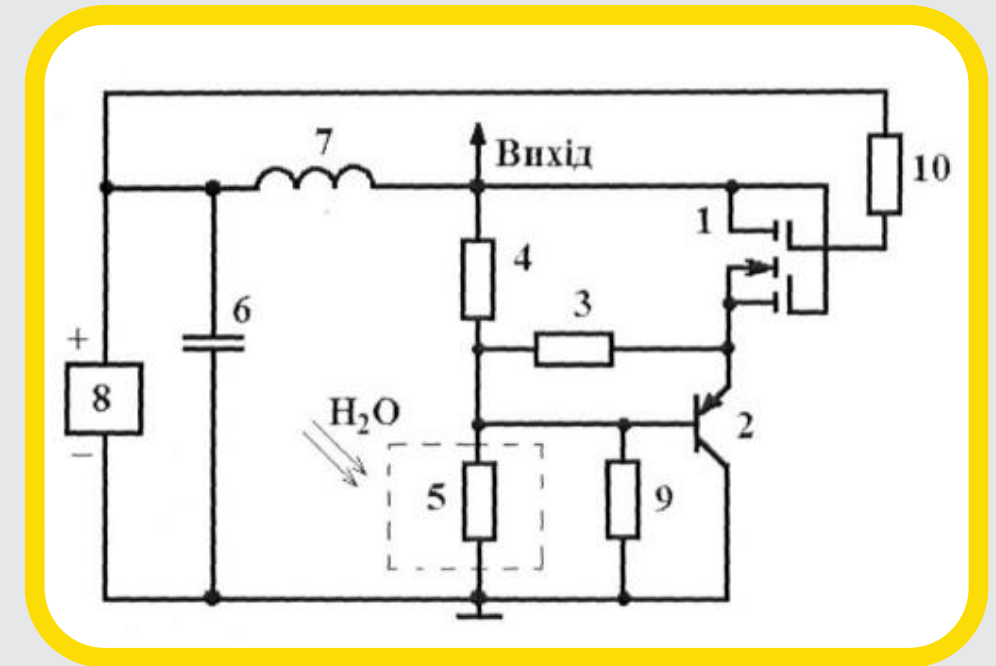

EXAMPLE:

Patent No. 129485

HUMIDITY MEASURING DEVICE

Utility model

An object of a utility model may be a device or a process (method).

Legal protection shall be granted to a utility model that does not contradict public order or generally accepted principles of morality and meets the patentability requirements.

A utility model meets the patentability requirements if it is:

- new;
- industrially applicable.

The term of validity of intellectual property rights to a utility model shall be **10 years** from the filing date of the application.

A patent is a title of protection.

The fee for filing an application (international application) for a utility model containing no more than three claims is **UAH 2,600**.
An additional fee of **UAH 240** shall be paid for each claim in excess of three.

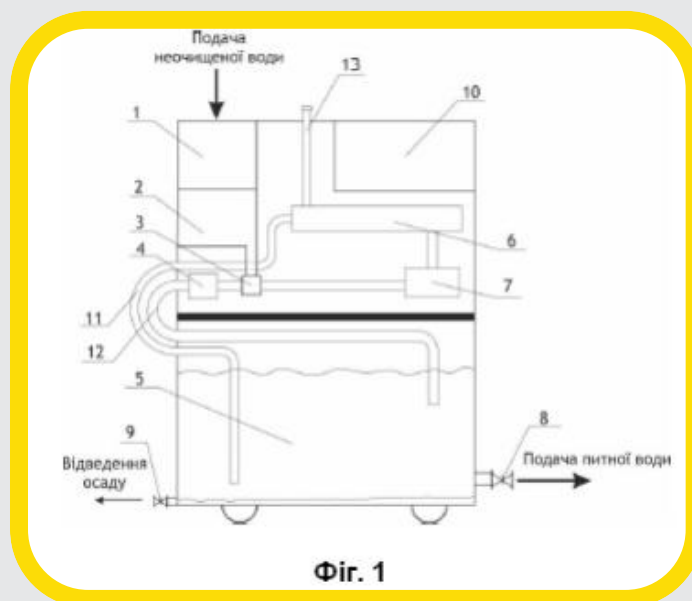

EXAMPLE

Patent No. 158928

DEVICE FOR PURIFYING AND PREPARING WATER FOR CONSUMPTION

Industrial design

The design and appearance of a product may be protected as industrial designs. In Ukraine, intellectual property rights to an industrial design arise once it has been made available to the public. However, registration of rights to an industrial design provides a significant advantage in any disputes, particularly on online marketplaces.

An industrial design is the result of a person's intellectual and creative activity in the field of industrial design.

The subject matter of an industrial design may be the appearance of a product or a part thereof, determined, in particular, by the lines, contours, colours, shape, texture and/or materials of the product, and/or its ornamentation.

Legal protection shall be granted to an industrial design that does not contradict public order or generally accepted principles of morality and meets the requirements for protection.

An industrial design meets the requirements for protection if it:

- is new;
- has an individual character.

The fee for filing an application for a design comprising a single design is UAH 1,600.



EXAMPLE
Certificate No. 46753
BOTTLE WITH A LID

Industrial design

An industrial design may obtain legal protection as:

- a registered industrial design;
- an unregistered industrial design, provided that it has been made available to the public.



The term of legal protection of an unregistered industrial design shall be 3 years from the date on which it was made available to the public in the territory of Ukraine.



The term of validity of intellectual property rights to a registered industrial design shall be 5 years from the filing date of the application and may be extended, at the request of the owner of the industrial design, for one or more additional five-year periods, subject to payment of the prescribed fee, but not exceeding 25 years in total.

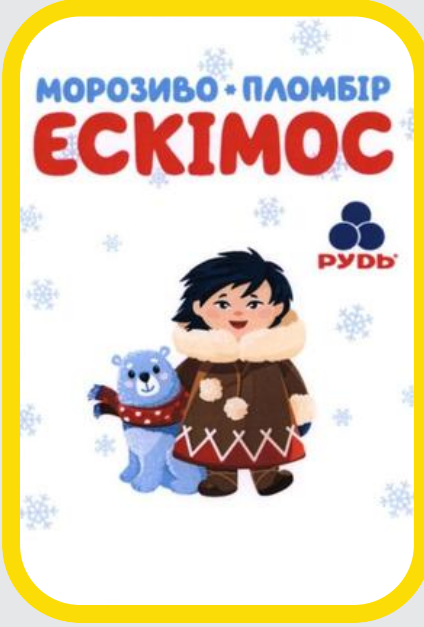

Geographical indications

A geographical indication ensures recognition both in domestic and international markets. It protects regional traditions and the unique characteristics of a product or its production. Products from other regions may be similar, but they cannot bear the same name. Unlike a trademark, a geographical indication protects a territory rather than an individual producer.



ZAKARPATTIA HONEY



ZAKARPATTIA WINE



FRUMUSHYKA LAMB



MELITOPOL MERRY



KROLEVETS TOWELS



HUTSUL SHEEP BRYNDZA

IP strategy

DO YOU KNOW WHAT DISTINGUISHES SUCCESSFUL COMPANIES FROM THE REST?

IT IS THEIR ABILITY TO PROTECT AND MONETIZE THEIR UNIQUE IDEAS – EFFECTIVE MANAGEMENT OF THEIR MOST VALUABLE ASSET – INTELLECTUAL PROPERTY.



**WHAT SHOULD YOU
FOCUS ON?**

IP strategy

An IP strategy is an action plan aimed at identifying, protecting, enforcing and commercializing intellectual property objects for the purpose of:

- achieving desired results through selecting the form of use of the created innovative product, determining the field of its application and capturing a certain market share
- improving the financial performance through the development and use of intellectual property objects
- enhancing the company's competitiveness through the use of new technologies in the production of goods and services

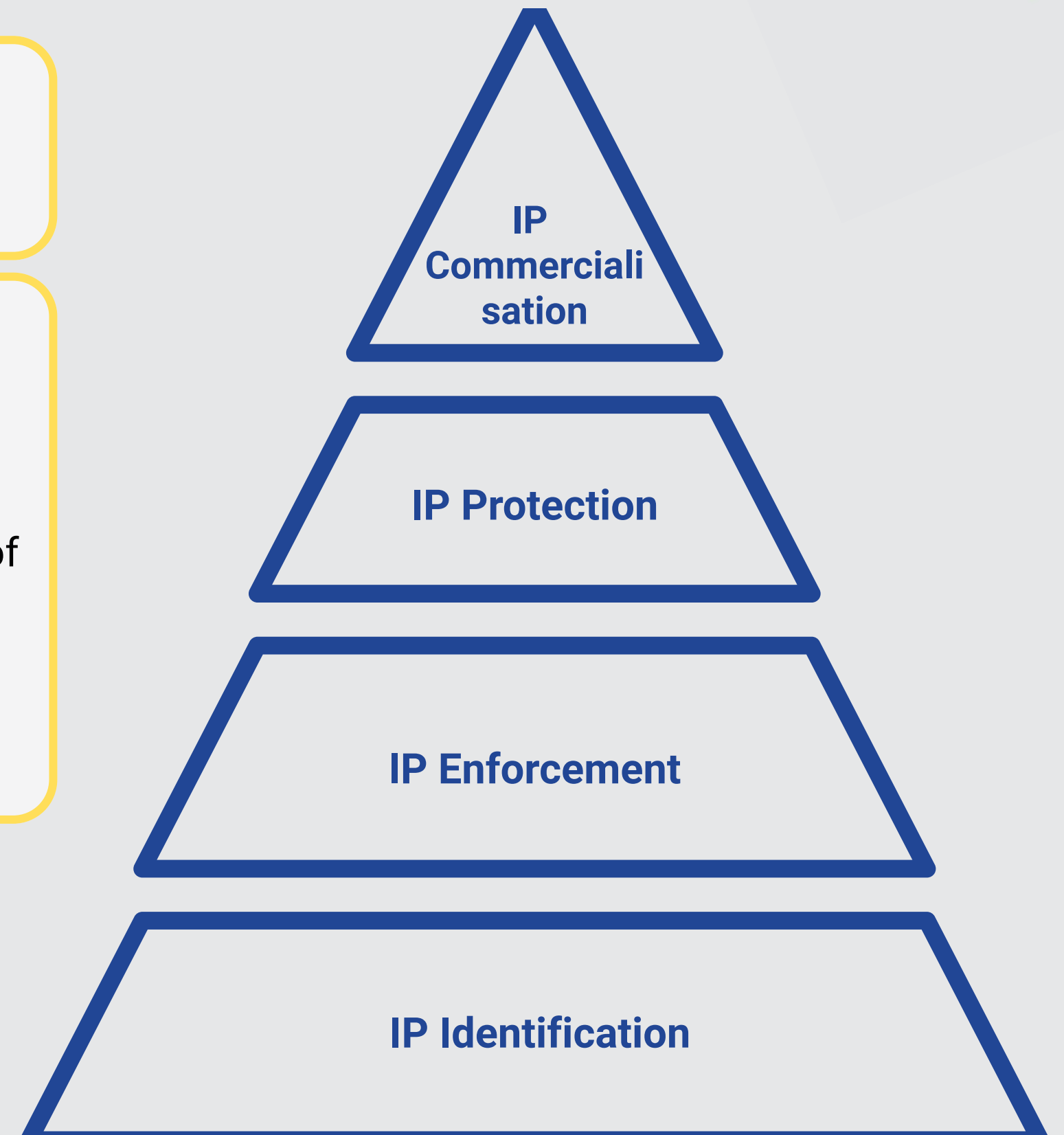

A

24/7 online filing of documents and application status tracking through your personal account

C

**Thematic and information searches (based on agreed categories)
Freedom-to-operate (FTO) search**

B

Patent research and analysis

D

Advisory support on general matters related to the preparation and filing of applications for intellectual property protection, as well as information acceleration services.

WHAT WE OFFER

APPLICANTS

Detailed information is available in the UANIPIO list of paid services:



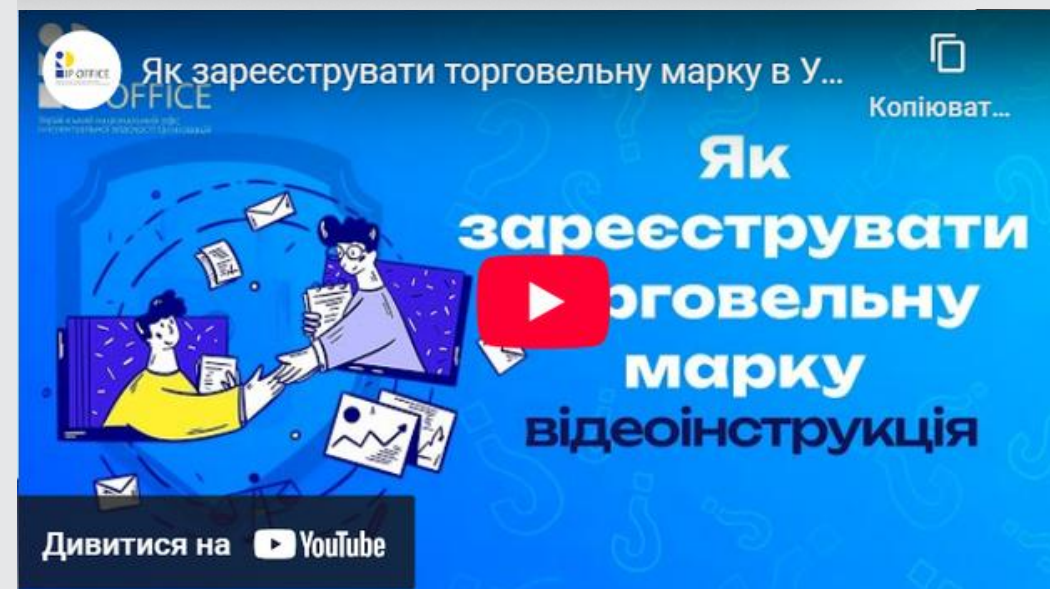
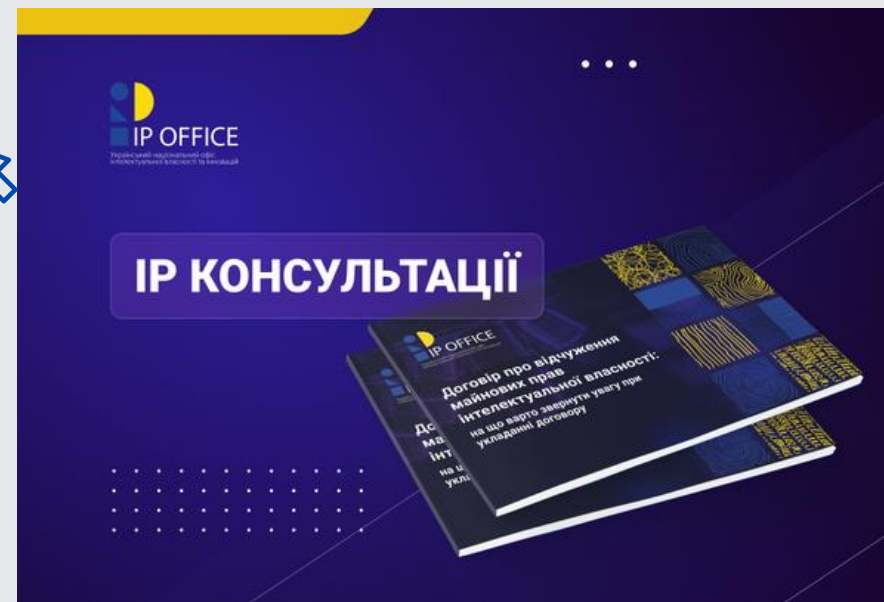
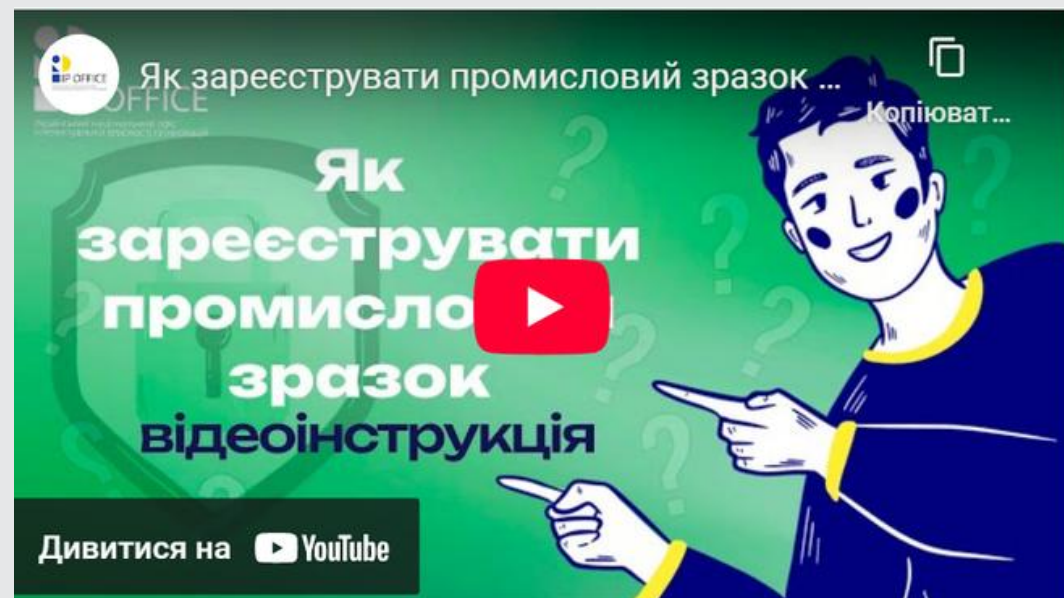
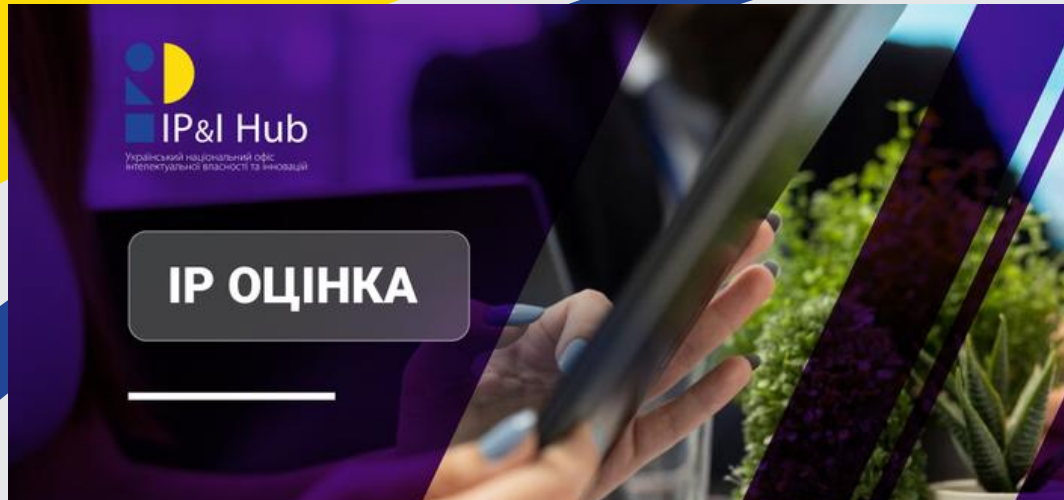

GUIDES AND FORMS FOR THE REGISTRATION OF RIGHTS TO INTELLECTUAL PROPERTY OBJECTS

STANDARD AGREEMENT TEMPLATES

IP VALUATION

VIDEO TUTORIALS

A

Professional **valuation of intellectual property rights** for balance sheet recognition, contribution to authorised capital, and determination of royalty rates

B

Information and advisory support, as well as contract analysis in the field of technology transfer.

C

Applicant's personal account

D

Patent research and analysis

WHAT WE OFFER

BUSINESS AND SMES

E

Thematic and patent searches (based on agreed categories)
Freedom-to-operate (FTO) search

F

Support for applications for reimbursement of expenses related to the registration of intellectual property objects under the **EUIPO SME Fund**: advisory support, document package preparation and portal account creation.

G

Mechanisms for partial reimbursement of expenses related to the protection of intellectual property rights are being implemented **for SMEs** at the national and regional levels.

H

IP&I Guide: a step-by-step guide for entrepreneurs on innovation and intellectual property

For business and SMEs



IP Catalog Green Tech UA

Враховуючи інноваційну складову діяльності, IP офіс публікує інформацію щодо заявок та виданих патентів на винаходи, що належать до сфери екологічно чистих (зелених) технологій.

IP офіс (УКРНОІВІ) / 3 лип.



IP INTERACTIVE



IP гайд для бізнесу: ЗАКОННЕ ВИКОРИСТАННЯ МУЗИКИ

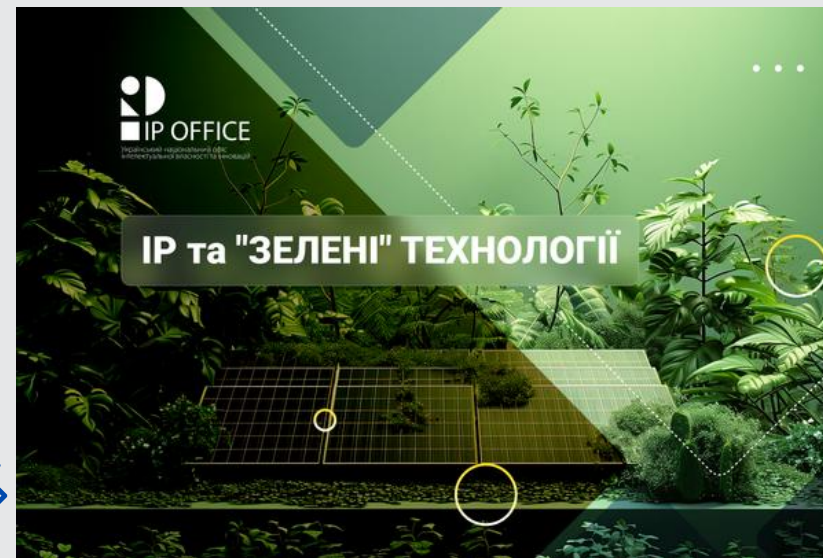

IP та "ЗЕЛЕНІ" ТЕХНОЛОГІЇ



ТЕХНОЛОГІЇ: 2019-2024

ІНФОРМАЦІЙНО-АНАЛІТИЧНА ДОВІДКА

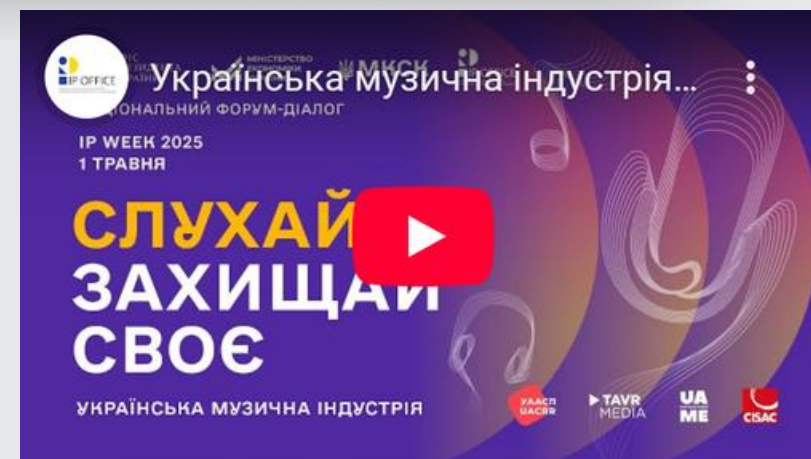

Українська музична індустрія...
НАЦІОНАЛЬНИЙ ФОРУМ-ДІАЛОГ

IP WEEK 2025
1 ТРАВНЯ

СЛУХАЙ ЗАХИЩАЙ СВОЄ

УКРАЇНЬСЬКА МУЗИЧНА ІНДУСТРІЯ



UA IP LET FORUM 2024: III Націон...
2-3 листопада 2024 | Київ

IP LET FORUM

INTELLECTUAL PROPERTY: LAW
ECONOMY
TECHNOLOGY

Informational partner



INFORMATION REPORTS

INTERACTIVE IP AND
INNOVATION DASHBOARDS

IP GUIDES FOR BUSINESSES

TECHNOLOGY ANALYSIS

INTERNATIONAL AND
NATIONAL FORUMS

A

At the idea stage, support for innovators includes **IP awareness activities**, development of innovative thinking and understanding of commercialisation, **including IP Academy training programmes and TISC network events**.

B

Free access to TISC centres for information and advisory support on IP and innovation issues, as well as **startup support**.

C

Project management (PRO management)

D

Support for an innovation project/startup

E

Development of **guidelines, strategies and policies** on intellectual property and innovation activities.

F

Support and assistance in the preparation of **applications and grant management** for the funding of innovative projects.

G

Lab2Market is an adapted training programme that helps researchers acquire the knowledge needed to commercialise research results and bring them to market.

H

Technology Transfer Advisory Support

WHAT WE OFFER

SCIENCE AND STARTUPS

Science and Startups



STARTUP CREATION GUIDES FOR HIGHER EDUCATION AND RESEARCH INSTITUTIONS

IP POLICY FOR HIGHER EDUCATION AND RESEARCH INSTITUTIONS

IP AND INNOVATION NEWS DIGESTS

SUMMER SCHOOLS ON IP AND INNOVATION

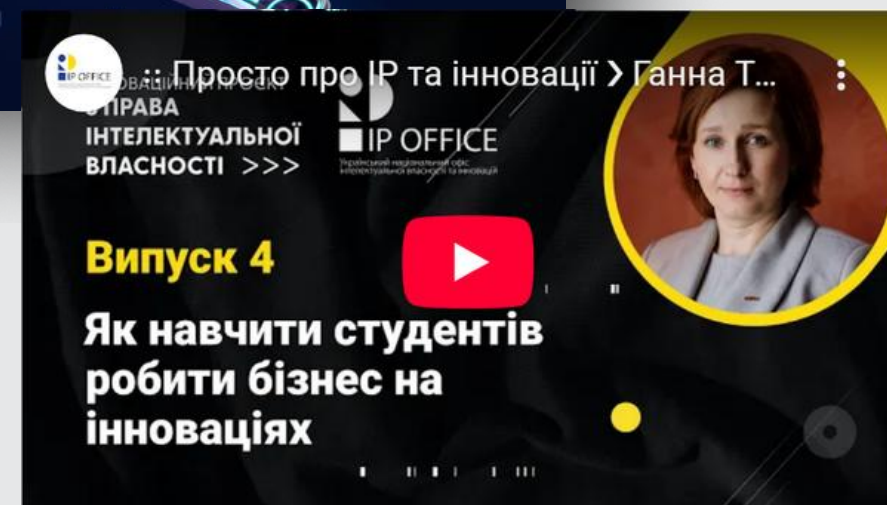
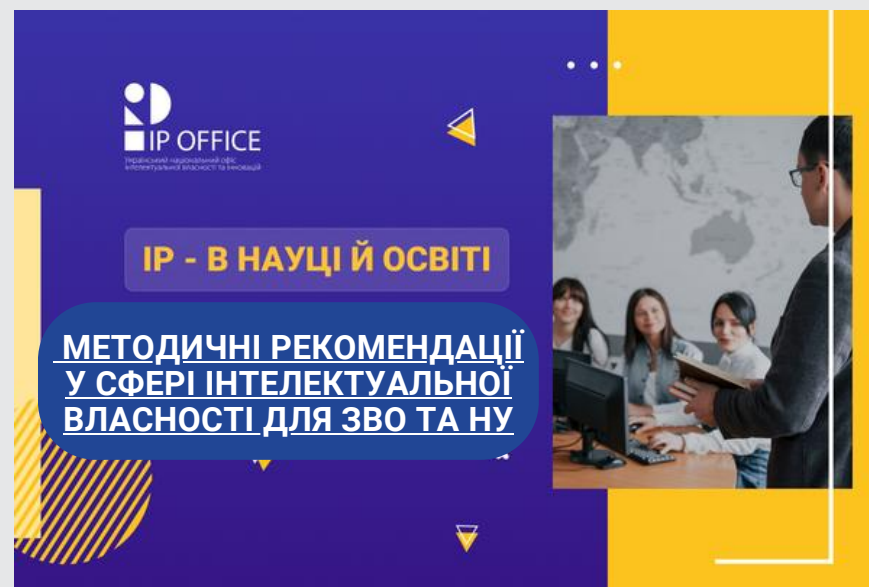

The UANIPIO team provides support and advisory services for grant competitions under national, regional and international programmes to ensure effective project management, support project implementation, foster partnerships and facilitate entry into new markets.

SME Fund 2026 is a grant programme and initiative of the European Commission, implemented by the European Union Intellectual Property Office (EUIPO), aimed at supporting **small and medium-sized enterprises in obtaining legal protection for intellectual property objects.**

Mechanisms for partial reimbursement of expenses related to the protection of intellectual property rights are being implemented for small and medium-sized enterprises (SMEs) at the national and regional levels.



Тип ваучера	Сума для відшкодування
Торговельні марки та промислові зразки - Trade marks and designs	€700
Національні патенти та пошуки рівня техніки і попереднього рівня техніки - National Patents and Prior Art Searches	€1 000
Європейські патенти та юридичні послуги - European Patents and Legal	€2 500

Lab2Market UA Acceleration programme

Lab2Market is an adapted training programme that helps researchers acquire the knowledge needed to commercialize research results and bring them to market.

Goal: to help participants “step out of the lab”, interview potential clients, partners, and other stakeholders, and explore the possible applications of their developments under the guidance of mentors.



scientists



researchers



inventors



entrepreneurs, early-stage startups



technology transfer managers of higher education and research institutions

Lab2Market UA 1.0 - 2023



Lab2Market UA 2.0 - 2024



Lab2Market MedTech - 2025



Lab2Market AgroTech - 2026



Lab2Market Veterano Acceleration programme

The Lab2Market Veterano project was created to help veterans, active military personnel, and their family members become business innovators by addressing gaps in their entrepreneurial knowledge with a focus on innovation.

The goal of the project is to provide veterans with the knowledge and skills necessary to successfully engage in innovative entrepreneurship and to support their reintegration into civilian life by opening new opportunities for self-realization and contribution to the country's economy.

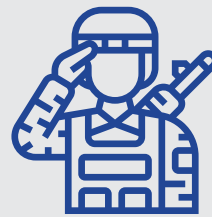

combat veterans (since 2014)



active military personnel



their family members interested in pursuing innovative business activities



veterans

Lab2Market Veterano, Dnipro 2024



Lab2Market Veterano, Vinitsya 2025



Lab2Market Veterano, Lutsk 2026



Capacity building for the commercialisation of university-developed innovative technologies

The IP Office, together with American partners, launched a pilot programme entitled “Capacity Building for the commercialisation of University-Developed Innovative Technologies.”

The programme aims to enhance the commercialisation of innovative technologies and support the development of regional innovation hubs.



Participants in the pilot programme include regional innovation hubs established at the following universities:

- National Technical University Dnipro Polytechnic;
- Zhytomyr Polytechnic State University;
- Lutsk National Technical University (LNTU).



Representatives of universities and their innovation hubs will gain knowledge and practical skills, based on the expertise of the programme team, in the following areas:

- intellectual property management at universities;
- university IP policies;
- drafting agreements on the commercialisation of intellectual property;
- negotiation practices in the field of technology transfer;
- and related areas.





Head of the Innovation Development Department
of the State Organization "Ukrainian National Office
for Intellectual Property and Innovations (UANIPIO)"

✉ olha.kronda@nipo.gov.ua

☎ + 38 (044) 495-05-24,

UANIPIO website



**UANIPIO Facebook
page**



**Advisory services
through the
Diia.Business portal**



+380 (44) 494-05-51



office@nipo.gov.ua



1 Dmytra Hodzenka Street, Kyiv, Ukraine